

SILICON DETECTOR DIODE

DESCRIPTION:

The **MA41202C** is a High Burnout Point Contact Mixer Diode.

MAXIMUM RATINGS

I	20 mA
V	1.0 V
P_{DISS}	10 ERGS @ T _C = 25 °C
T_J	-55 °C to +150 °C
T_{STG}	-55 °C to +150 °C

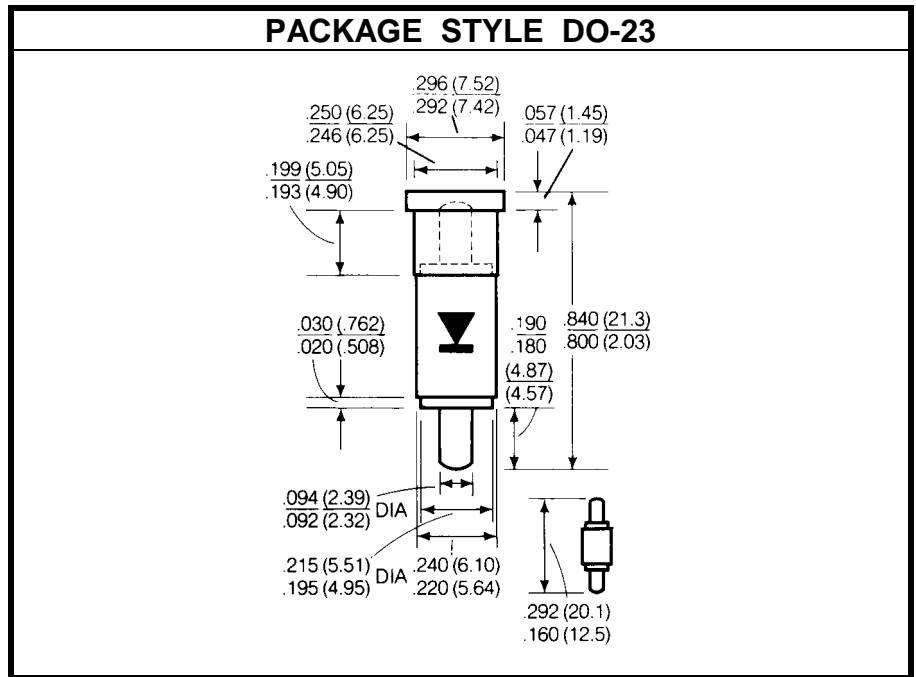
CHARACTERISTICS T_C = 25 °C

SYMBOL	TEST CONDITIONS	MINIMUM	TYPICAL	MAXIMUM	UNITS
N_F	OVERALL NOISE FIGURE			9.8	dB
C_L	CONVERSION LOSS			6.5	dB
V_{SWR}	VOLTAGE STANDING WAVE RATIO			1.5	---
Z_{IF}	I _F IMPEDANCE	335		465	Ω
f_{Range}	N _{if} = 1.5 dB R _L = 100 Ω f = 9.375 GHz	8.2		12.4	GHz