

# NPN SILICON RF POWER TRANSISTOR

**DESCRIPTION:**

The **MRW53601** is Designed for Class "A" and "AB" Amplifier Applications Up to 2.0 GHz.

**MAXIMUM RATINGS**

<b>I</b>	250 mA
<b>V</b>	22 V
<b>T<sub>J</sub></b>	-65 °C to +200 °C
<b>T<sub>STG</sub></b>	-65 °C to +200 °C
<b>θ<sub>JC</sub></b>	40 °C/W

PACKAGE STYLE HLP-1				
Dim:	Millimeters		Inches	
	Min	Max	Min	Max
A	0.790	0.810	20.07	20.57
B	0.240	0.260	6.10	6.60
C	0.144	0.170	3.66	4.31
D	0.115	0.125	2.93	3.17
E	0.055	0.065	1.40	1.65
F	0.045	0.055	1.15	1.39
H	0.115	0.135	2.93	3.42
J	0.003	0.006	0.08	0.15
K	0.225	0.275	5.72	6.98
N	0.220	0.240	5.59	6.09
Q	0.125	0.135	3.18	3.42
U	0.552	0.572	14.03	14.52

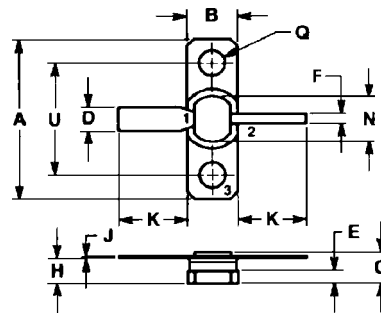

1 = Base    2 = Collector  
3 = Emitter

**CHARACTERISTICS**  $T_C = 25\text{ }^\circ\text{C}$ 

SYMBOL	TEST CONDITIONS		MINIMUM	TYPICAL	MAXIMUM	UNITS
<b>BV<sub>CEO</sub></b>	$I_C = 10\text{ mA}$		22			<b>V</b>
<b>BV<sub>CES</sub></b>	$I_C = 10\text{ mA}$		50			<b>V</b>
<b>BV<sub>CBO</sub></b>	$I_C = 1.0\text{ mA}$		45			<b>V</b>
<b>I<sub>CBO</sub></b>	$V_{CB} = 28\text{ V}$				250	<b>μA</b>
<b>BV<sub>EBO</sub></b>	$I_E = 250\text{ μA}$		3.5			<b>V</b>
<b>h<sub>FE</sub></b>	$V_{CE} = 5.0\text{ V}$	$I_C = 100\text{ mA}$	20		120	<b>---</b>
<b>f<sub>t</sub></b>	$V_{CE} = 20\text{ V}$	$I_E = 120\text{ mA}$		3.0		<b>GHz</b>
<b>C<sub>ob</sub></b>	$V_{CB} = 28\text{ V}$	$f = 1.0\text{ MHz}$			3.5	<b>pF</b>
<b>G<sub>PE</sub></b> <b>L<sub>G</sub></b>	$V_{CE} = 20\text{ V}$ $f = 2.0\text{ GHz}$	$I_{CQ} = 120\text{ mA}$	$P_{out} = 0.5\text{ W}$	10		<b>dB</b>
					-0.2/+1.0	